

United States Coast Guard Auxiliary

Strategic Plan 2016 – 2022



01 November 2016

This page intentionally left blank



THE COMMANDANT OF THE UNITED STATES COAST GUARD
WASHINGTON, D.C. 20593-0001

To the Men and Women of the Coast Guard Auxiliary:

I offer my heartiest congratulations to our Coast Guard uniformed volunteers for your development and implementation of the 2016-2022 Coast Guard Auxiliary Strategic Plan. This plan charts the comprehensive course which the Auxiliary must travel in order to maintain its place as the world's premiere volunteer maritime service providing superior readiness, capability, and support.

As is true for any strategic plan, its value can only be derived from the steadfast and concerted efforts of those upon whom its execution relies. I strongly encourage all Auxiliarists and implementing partners to read the 2016-2022 Coast Guard Auxiliary Strategic Plan, embrace its purpose and objectives, and follow its prescribed way points. Diligently implementing the Strategic Plan will demonstrate your Service to Nation, Duty to People, and Commitment to Excellence and provide the highest return to the American public.

Sincerely,

Paul F. Zukunft /s/
Admiral, U.S. Coast Guard



THE NATIONAL COMMODORE
UNITED STATES COAST GUARD AUXILIARY
Richard Washburn



Foreword

From the National Commodore

I am pleased to present the 2016-2022 U.S. Coast Guard Auxiliary Strategic Plan to the 25,300 plus member volunteer force and to the U.S. Coast Guard as a whole. The Auxiliary has consistently proved its organizational resiliency and demonstrable capacity to handle significant challenges. It has considerably diversified its support to Coast Guard missions, units, and personnel and has greatly helped the Coast Guard address mounting strategic concerns such as marine safety and security, environmental protection, and cyber security across the maritime transportation system.

The U.S. Coast Guard's respect and appreciation for our Auxiliary shipmates is buttressed by the U.S. Coast Guard Auxiliary Policy Statement. It provides the foundation of recognition and support for the tremendous service, sacrifice, and commitment that Auxiliarists readily provide the Coast Guard every day. The significance and value of Auxiliary support to recreational boating safety, search and rescue, marine safety, security, and environmental protection, maritime domain awareness, waterways and coastal security, and many other Coast Guard missions have never been greater, and remains essential to our Nation's maritime homeland security.

This Strategic Plan charts the course for Auxiliary administration and program management. It outlines the duties, responsibilities, and expectations of Auxiliarists as they deliver vital services and assist the Coast Guard in shaping, preparing, and applying its mission capabilities to the 21st century mission challenges. I continue to wish you all the best as you carry out your duties and responsibilities in support of the Coast Guard and the Nation. Your unparalleled support and dedicated mission focus are profoundly appreciated. *Semper Paratus!*

Richard A. Washburn /s/
National Commodore
U.S. Coast Guard Auxiliary



Mission



Leadership



Excellence

Contents

Executive summary	6
U.S. Coast Guard Auxiliary Policy Statement	7
Missions and Vision	8
Auxiliary overview	8
Coast Guard Auxiliary Areas, Districts and Regions	12
Coast Guard Auxiliary Organizational Chart	13
Core Values	14
Watchwords	14
Guiding Principles and Priorities	15
Service to nation	15
Duty to people	15
Commitment to excellence	15
Oversight and Implementation	17
Assistant National Commodore – Response and Prevention	18
Assistant National Commodore – Recreational Boating	20
Assistant National Commodore – ForceCom	22
Assistant National Commodore – Planning and Performance	23
Assistant National Commodore – Information Technology	25
National Executive Committee	26

Executive Summary

In this, its 77th year of operations, the United States Coast Guard Auxiliary, the 25,300-strong uniformed volunteer component of the United States Coast Guard, embraces its vision to have its people be the best trained, most valued maritime volunteer organization in the world. It will be prepared to effectively meet Mission needs, Service needs and People needs. The Auxiliary will execute its responsibilities efficiently in support of operational goals and missions, ready to meet normal operations and surge demands. It will work to attract, develop and retain a diverse and inclusive force, providing relevant and rewarding opportunities to its members.

Answering the call to duty in performance of its missions, the Auxiliary incorporates the guiding principles of the Commandant's Direction 2014: Service to Nation, Duty to People, and Commitment to Excellence.

This strategic plan identifies the key challenges and opportunities the Auxiliary faces, as well as the objectives established to meet the challenges and take advantage of the opportunities presented.

In its Service to Nation, the Auxiliary will stress outreach, including enhancing efforts in water safety, particularly for paddlecraft; education to the recreational boating public in concurrence with the Strategic Plan of the National Recreational Boating Safety Program; and establishing new mission capacity in support of multiple Coast Guard initiatives, providing a capable and well-trained workforce.

In its Duty to People, the Auxiliary will streamline organization processes, technology and administration to remove roadblocks to productivity, allowing members to focus on missions and training, in line with the Coast Guard's Human Capital Strategy's priorities: Meet Mission Needs, Meet Service Needs, and Meet People Needs.

In its Commitment to Excellence, the Auxiliary will establish new leadership training and nurture its culture via servant leaders. To provide the Auxiliary and Coast Guard with young, talented, educated, diverse and well-trained leaders, the Auxiliary will expand the Auxiliary University Program. To provide excellence in mission support to the Coast Guard, the Auxiliary will align its Interpreter Corps capabilities with Coast Guard requirements and will enhance its abilities in maritime radio communications support. To insure fiscal responsibility and compliance, a Chief Financial Officer will be assigned to manage national financial strategies and administration.

As the Auxiliary operationalizes its strategic plan, the watchwords "Mission," "Leadership," and "Excellence" point the way to the future.



THE COMMANDANT OF THE UNITED STATES COAST GUARD
Washington, DC 20593

U.S. COAST GUARD AUXILIARY POLICY STATEMENT

The U.S. Coast Guard Auxiliary is the uniformed volunteer component of our Service. The Coast Guard's guiding principles of SERVICE TO NATION, DUTY TO PEOPLE and COMMITMENT TO EXCELLENCE are only achievable through the combined efforts of all Coast Guard forces. The Coast Guard Auxiliary is a valuable, dedicated and indispensable part of the Coast Guard team.

Established by Congress on June 23, 1939, as the Volunteer Reserve, the Auxiliary conducted many of the Coast Guard's domestic missions while the Active Duty and Reserve components were forward deployed during World War II. The Auxiliary has continued its great service to our Nation ever since.

The spirit of volunteerism and patriotism that called the first Auxiliarists to duty continues today in the more than 30,000 professional men and women who faithfully execute assigned Auxiliary missions throughout our Nation, its territories, and in foreign countries where U.S. engagement is enhanced by Auxiliary services. Upon enrollment, Auxiliarists pledge to support the Coast Guard Auxiliary and to faithfully execute assigned duties, and to abide by the governing policies established by the Commandant. They are a crucial force multiplier for the Coast Guard's sustained mission excellence.

Auxiliarists enthusiastically provide experience, talent, and platforms for a wide range of activities, including, Maritime Safety Outreach, Search and Rescue, Safety and Security Patrols, Disaster Response, Pollution Response and recruiting. These activities enable the Coast Guard to successfully execute all its mission, and they do it without compensation!

The Auxiliary missions are:

- To promote and improve Recreational Boating Safety;
- To provide a diverse array of specialized skills, trained crews, and capable facilities to augment the Coast Guard and enhance safety and security of our ports, waterways and coastal regions;
- To support Coast Guard operational, administrative and logistical requirements.

I charge all Commanders, Commanding Officers and Officers in Charge to continually strive to include the Auxiliary in mission execution and support so that we can maximize sustained excellence across all mission areas.

PAUL F. ZUKUNFT /s/
Admiral, U.S. Coast Guard

Mission and Vision

Mission

- To promote and improve Recreational Boating Safety
- To provide a diverse array of specialized skills, trained crews, and capable facilities to augment the Coast Guard and enhance safety and security of our ports, waterways, and coastal regions
- To support Coast Guard operational, administrative, and logistical requirements

Vision

The United States Coast Guard Auxiliary – the best trained, most valued maritime volunteer organization in the world – highly effective during normal operations and ready for emergencies.

Auxiliary Overview

Established by Congress in 1939 under title 14, chapter 23 of the U.S. Code, the United States Coast Guard Auxiliary is *Semper Paratus* (Always Ready).

When the Coast Guard “Reserve” was authorized by act of Congress on June 23, 1939, the Coast Guard was given a legislative mandate to use civilians to promote safety on and over the high seas and the nation's navigable waters.

Two years later on February 19, Congress amended the 1939 act with passage of the Auxiliary and Reserve Act of 1941. Passage of this act designated the Reserve as a military branch of the active service while the civilian section, formerly referred to as the Coast Guard Reserve, became the Auxiliary under title 14, chapter 23 of the USC.

When we entered World War II, 50,000 Auxiliary members joined the war effort as military teams. Many of their private vessels were placed into service in an effort to protect the U.S.

Missions and Programs

Academy Introduction Mission (AIM). Auxiliarists are authorized assignment-to-duty to assist the Coast Guard Academy with recruitment of cadet candidates. This assignment includes orienting and counseling high school students, attending college fairs and participating in AIM Week each summer at the US Coast Guard Academy (USCGA).

Administrative Support to the Coast Guard. Auxiliarists are authorized assignment-to-duty to assist and to augment administrative functions of any Coast Guard unit.

Aids to Navigation (ATON). Qualified Auxiliaries and their facilities are authorized assignment-to-duty to support and augment the Coast Guard's ATON Program. After training and qualifying as an Aids Verifier, Auxiliaries verify the position and characteristics of private aids to navigation (PATONs) and help the National Ocean Service (NOS) and the U.S. Army Corps of Engineers in updating nautical and aeronautical charts. Members also support ATON units in servicing federal aids after receiving Coast Guard training. ATON units also help the National Ocean Service (NOS) and the U.S. Army Corps of Engineers in updating nautical and aeronautical charts.

America's Waterway Watch Program (AWW). Individuals and families are invited to participate in this program that is a nationwide initiative similar to the well-known Neighborhood Watch program that asks community members to report suspicious activities to local law enforcement agencies.

Bridge Administration. Qualified Auxiliaries and their facilities are authorized to

- ❖ Support and augment bridge surveys
- ❖ To investigate and to provide information regarding waterways safety and navigation situations pertaining to the bridge program
- ❖ To provide direct assistance and support to bridge program staff and other Coast Guard personnel in the Bridge Administration Program

Contingency Preparedness. Qualified Auxiliaries and their facilities are authorized to provide platforms and personnel for defense and non-defense exercises and to develop plans and support contingency response operations for disaster and lesser incidents. Auxiliaries and their operational facilities may also provide support as unarmed opposition forces (OPFOR) and gather information and data for contingency plans.

Merchant Mariner Licensing. Qualified Auxiliaries are authorized to administer merchant mariner license and document examinations in remote areas, to conduct oversight of approved maritime training courses, and to provide administrative support for the marine licensing program at the local level.

Marine Environmental Protection and Safety (MEP). Qualified Auxiliaries and their facilities assist with marine environmental protection and safety programs and pollution prevention and environmental disaster relief operations. Auxiliaries, when qualified and approved, may assist in a variety of Coast Guard maritime inspection programs.

Operational Support to the Coast Guard (OPS). Qualified Auxiliaries and their facilities are authorized to support all Coast Guard operational units. Auxiliaries must be qualified per current Coast Guard and Auxiliary manuals and directive provisions and must serve under an active duty unit commander's direction.

Port Safety and Security (PS&S). Qualified Auxiliarists and their facilities are authorized to support the Port Safety and Security Program. Auxiliarists may provide facilities and unarmed personnel for

- ❖ Surveillance and reporting
- ❖ Harbor and anchorage patrols
- ❖ Assistance to Coast Guard forces in safety and security zone enforcement
- ❖ Support for vessel boarding
- ❖ Port facility and vessel verification visits
- ❖ Aircraft over-flights augmenting Coast Guard crews
- ❖ Administrative support

Public Affairs Support (PA). Auxiliarists are authorized to support both Coast Guard and Auxiliary public affairs programs.

Public Education. The Education Directorate's mission is twofold:

- ❖ To provide exceptional boating safety education to America with the aim of reducing loss of life, personal injury, and property damage to recreational boaters
- ❖ To deliver the highest possible quality training, resources and timely materials in support of our flotilla instructors and public education staff officers at every level who are furnishing such boating safety education

Recreational Boating Safety (RBS). Qualified Auxiliarists and their facilities may be assigned to support the recreational boating safety program by:

- ❖ Conducting public education
- ❖ Performing recreational Vessel Safety Checks (VSCs)
- ❖ Participating in State Liaison Programs
- ❖ Participating in marine program visitations (PVs), boat shows and National Safe Boating Week (NSBW) activities

Recruiting. Auxiliarists may qualify and be assigned-to-duty as military recruiters to support the Coast Guard's recruiting program. This assignment includes qualification as a military recruiter, proctoring recruiting examinations, and administrative assistance to recruiting.

Search and Rescue. Qualified Auxiliarists and their facilities are authorized to assist the Coast Guard in support of search and rescue operations. These duties include search planning, search operations, and the conduct of rescues at sea.

Training for Sea Cadets and Sea Scouts. Coast Guard Auxiliary members are authorized to provide shore side and underway training to Sea Cadets and Sea Scouts, under a program that is an outgrowth of the Auxiliary's Memorandum of Understanding (MOU) with the Naval Sea Cadet Corps (NSCC), and its Memorandum of Agreement (MOA) with the Boy Scouts of America (BSA).

Inspections of commercial vessels. Qualified Auxiliarists assist the Coast Guard in marine inspection mission by:

- ❖ Supporting and assisting Coast Guard accident investigations
- ❖ Providing platforms for inspectors
- ❖ Conducting barge inspections
- ❖ Providing remote area surveillance and response
- ❖ Conducting voluntary examinations of uninspected commercial vessels
- ❖ Providing administrative and operational program support

Waterways Management. Qualified Auxiliarists are authorized to assist in Coast Guard waterways management mission areas by:

- ❖ Providing platforms and unarmed personnel for Coast Guard and other federal and state agencies
- ❖ Inputting information and data into the analysis process
- ❖ Providing administrative and operational program support for commercial vessels

In addition, the U.S. Coast Guard Auxiliary can perform any mission as directed by the Commandant of the U.S. Coast Guard or Secretary of Homeland Security except for law enforcement or military operations.

The Auxiliary has a presence in all 50 states, the District of Columbia, Puerto Rico, the Virgin Islands, American Samoa, and Guam.

Under the direct authority of the U.S. Department of Homeland Security via the Commandant of the U.S. Coast Guard, the Auxiliary's internally operating levels are broken down into four organizational levels: Flotilla, Division, District, and National.

- National – National, comprised of the National Board and National Executive Committee, is responsible under the governing policies established by the Commandant of the Coast Guard for the administration and policy direction for the Auxiliary. The National Staff manages the missions, programs, and policies.

U.S. COAST GUARD AUXILIARY AREAS, DISTRICTS, AND REGIONS

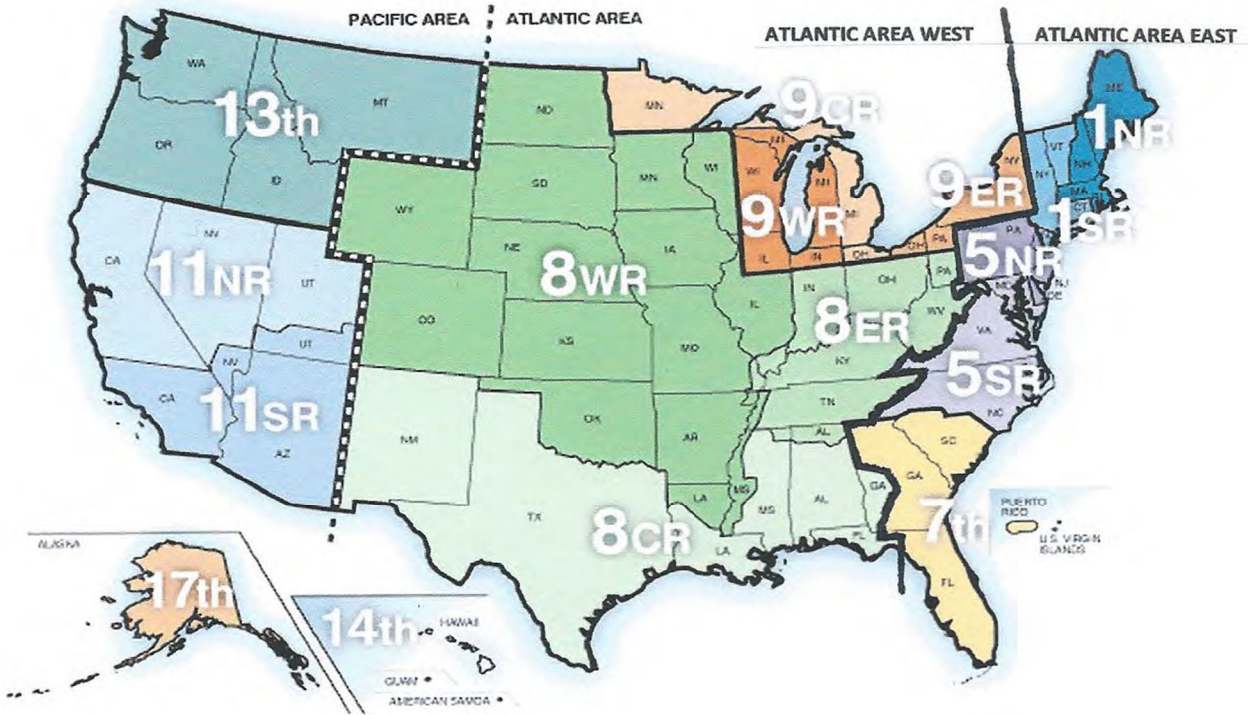

- District -The District provides administrative and supervisory support to Divisions and promotes District and National policy.
- Division - Flotillas in the same general geographic area are grouped into Divisions. The Division provides administrative, training, and supervisory support to Flotillas and promotes District and National policy.
- Flotilla - The Flotilla is the basic organizational unit of the Auxiliary and is comprised of at least 15 qualified members, who perform the day-to-day activities of the unit. Members and facilities are based in Flotillas; every Auxiliary member belongs to a Flotilla.

U.S. Coast Guard Auxiliary Organization Chart

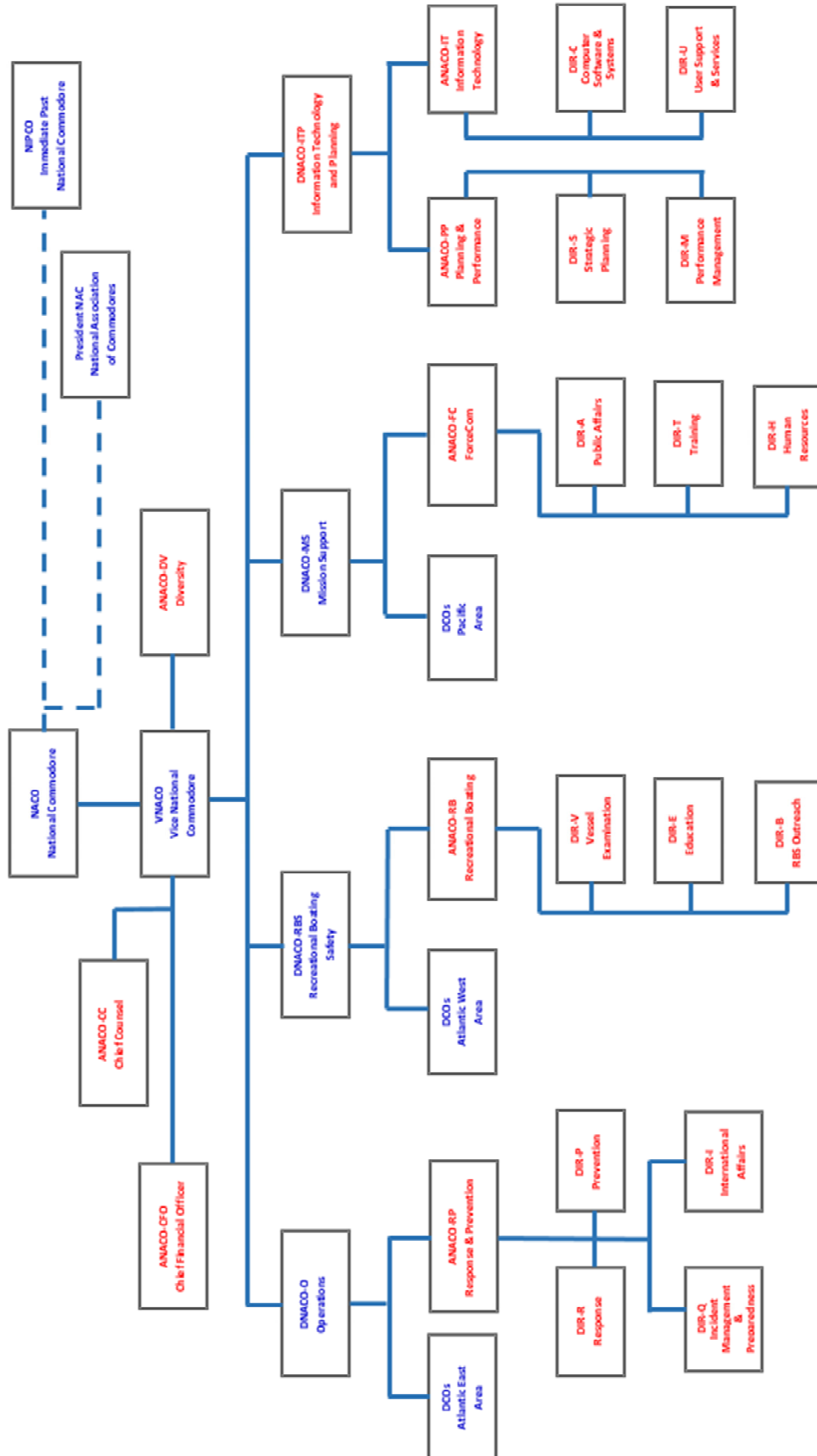

Core Values

Honor – Integrity is our standard. We demonstrate uncompromising ethical conduct and moral behavior in all of our personal and organizational actions. We are loyal and accountable to the public trust.

Respect – We value our diverse membership. We treat each other and those we serve with fairness, dignity, respect, and compassion. We encourage individual opportunity and growth. We encourage creativity through empowerment. We work as a team.

Devotion to Duty – We are volunteers who seek responsibility, accept accountability, and are committed to the successful achievement of our organizational goals. We exist to serve. We serve with pride.

WATCHWORDS

- **Mission**
Our members are trained and ready to execute all authorized Auxiliary missions according to exacting standards, providing the Coast Guard with an effective force-multiplier for normal, backfill and surge situations.
- **Leadership**
Proficiency in leadership, at all levels, is imperative. A focused development program of training, coaching and assessment is readily available to all members.
- **Excellence**
Recruiting, retaining, and rewarding excellence are essential. We foster a culture of excellence through inclusion and engagement to enable high quality performance, which is crucial to our ability to carry out missions.



Guiding Principles and Priorities

1. Service to Nation

- **Strengthen presence in all types of safe boating education**

Monitor the Auxiliary's Public Education products, modifying and expanding delivery of courses and products to proliferate safe boating behaviors within the recreational boating safety community.

- **Expand efforts in Paddlecraft Water Safety**

Increase Auxiliary presence and relevance in the growing paddlecraft community by collaborating with informed stakeholders, including the American Canoe Association, to promote on-the-water safety and reduce fatalities.

- **Meet Human Capital needs of the Coast Guard and the Auxiliary**

Provide qualified members to augment the mission, service and people needs of the Coast Guard.

2. Duty to People

- **Provide a unified web platform experience to facilitate meeting mission and people needs**

Implement tools and technology to simplify and standardize Auxiliary procedures.

- **Simplify, standardize, and coordinate administrative procedures to meet service and people needs**

Establish a formal and coordinated administrative function of management of the tools, processes and information.

- **Provide timely Auxiliary background checks**

Establish a formal and coordinated administrative process that facilitates timely and DHS compliant background checks.

3. Commitment to Excellence

- **Identify and provide leadership development resources, tools and training**

The best volunteer organization needs the best leaders, whether elected or appointed. Policy and resources will emphasize leadership training that is as important as job qualification training.

- **Maximize maritime radio communications support, capacity, and capabilities**

Implement effective and reliable Coast Guard communications support, particularly in areas with limited active duty presence.

- **Align Auxiliary Interpreter Corps capabilities with Coast Guard requirements**
Accurately meet specific Coast Guard interpretation requirements by identifying each Auxiliary interpreter's skills according to the Coast Guard's standard classification system.
- **Standardize, manage and support Auxiliary financial policies and procedures**
Define and implement sound financial process and procedures Auxiliary-wide, under a Chief Financial Officer. Provide qualified personal financial counseling to new Coast Guard members in support of the Coast Guard's move to a blended retirement plan.
- **Expand the Auxiliary University program to meet mission and service needs**
Provide the Coast Guard Auxiliary and Coast Guard with young, talented, educated, dedicated, diverse, and well-trained leaders to meet the service's operational and mission support needs.
- **Enhance the Coast Guard's Auxiliary information system of record to meet mission and service needs**
Provide the Auxiliary and Coast Guard with a secure and capable information system that meets the service's operational and mission support needs.

Oversight and Implementation

- **Collaborate** when a task is to be done – build a team, incorporate fellowship
- **Align** the task with regulation, policy, Auxiliary leadership, District or local Coast Guard commands
- **Engage** partners, public, other Auxiliary units and all stakeholders as necessary to get the aligned task accomplished

The Assistant National Commodore for Planning and Performance will oversee and coordinate the operationalization of the strategic priorities, reporting to the Vice National Commodore.

Assistant National Commodore – Response and Prevention

Maximize maritime radio communications support, capacity, and capabilities

Goal: Determine the requirements for implementing optimal communications support, supplying qualified watchstanders and facilities to provide maritime radio communications coverage, particularly in areas with limited Coast Guard presence.

Activities: Perform gap analyses to determine communications support requirements of Coast Guard units, for both normal operations and surge demands. Determine the corresponding Coast Guard Auxiliary capacity. Identify areas that are already providing effective support to use as models. Design and develop training and performance support systems that address the gaps.

Implementing Partners: The Auxiliary, including DNACO-O, ANACO-RP, DIR-R, DIR-P, DIR-Q, DIR-T, DIR-C, DCOs, and DCOSs, will partner with Assistant Commandant for Prevention Policy (CG-5P), Assistant Commandant for Response Policy (CG-5R), and Coast Guard commands.

Tactics and timeline:

- Assist the Districts with assessment of active duty needs and perform a gap analysis comparison of those needs against the available Auxiliary assets.
 - Work with on-going gap analysis process to ensure communications needs are included beginning 1 January 2017 – **ongoing**.
 - Work with on-going gap analysis process to ensure communications needs are included **by 1 February 2017**.
 - Review current gap analysis for identified needs by **1 June 2017**.
 - Review current gap analysis for information gaps by **1 June 2017**.
- Identify units already providing effective communications support; publish current best practices for watchstanding under Coast Guard orders in The Responder beginning **1 January 2017** and completing **31 November 2017** to include:
 - Watchstanding at Coast Guard commands (including air stations and marine safety units).
 - Watchstanding at remote Auxiliary locations to cover Coast Guard gap.
 - Providing radio guard for Auxiliary surface facilities.
- Develop a plan for finding, training and evaluating the resources necessary to meet Coast Guard needs.
 - Auxiliary teams assigned to each Coast Guard gap location beginning **1 Sept 2017** (i.e. sector=DSO-Q & R).
 - Leadership Link message to all members outlining the need for watchstanders and how to respond. **By 1 March 2017**.
 - Monthly team status reports with metrics beginning 1 January 2018 – **ongoing**.
- Implement the plan. Tactics and **dates TBD** after the plan is in place.
- Follow up with selected Active Duty counterparts to determine the effectiveness of the implementations. **Date TBD**.

Assistant National Commodore – Response and Prevention

Align Auxiliary Interpreter Corps capabilities with Coast Guard requirements

Goal: Accurately meet specific Coast Guard interpretation requirements by identifying each Auxiliary interpreter's skills according to the Coast Guard's standard classification system.

Activities: Evaluate and classify each member of the Interpreter Corps to identify their specific skill level within the Coast Guard's standard system, enabling a commonly understood criterion for providing specific interpreter skills.

Implementing Partners: The Auxiliary, including DNACO-O, ANACO-RP, DIR-I, and DIR-C, will partner with Director of International Affairs & Foreign Policy (DCO-I), Assistant Commandant for Prevention Policy (CG-5P), and Coast Guard Office of Auxiliary & Boating Safety (CG-BSX).

Tactics and timeline:

- Create standardized evaluation examinations by **1 December 2016**.
- Enhance the current interpreter evaluation process to classify each interpreter's abilities in alignment with Coast Guard standards by **30 March 2017**.
- Create a document of interpreters referenceable by skill level, geography and availability.
 - Input the document into the Coast Guard's system by **30 March 2017**.
 - Make regular updates to the document as interpreter staff changes. **Quarterly**.
- Develop pre-deployment course for Interpreters, and other Auxiliarists, covering the requirements of deployment by **30 June 2017**.
- Create a system to allow for Interpreter bi-annual evaluation by **1 October 2017**.

Assistant National Commodore – Recreational Boating

Strengthen presence in all types of safe boating education

Goal: Develop and deliver safe boating education that proliferates safe boating behaviors in order to increase public demand for traditional and e-courses.

Activities: Develop requirements and methods to evaluate current traditional and electronic educational products, and their use and acceptance by our customers and members. Develop an annual process for review of our educational products to ensure that they continue to meet public demand. Determine new courses to develop. Identify areas for collaboration with the US Power Squadrons (USPS). Be a key, preeminent implementing RBS partner in the 2017-2021 National Recreational Boating Safety Strategic Plan.

Implementing Partners: The Auxiliary, including DNACO-RBS, ANACO-RB, DIR-B, DIR-V, DIR-E, DIR-T, Auxiliary Association, DIR-C, and DIR-A, will partner with Assistant Commandant for Prevention Policy (CG-5P) and the USPS.

Tactics and timeline:

- Prepare a detailed plan for which courses will go through the NASBLA approval cycle by **1 December 2016**.
- Develop requirements and methods to evaluate current products, their use, and acceptance by customers and members by **31 December 2016**.
- Develop a detailed plan for how to determine what e-books, online courses and new classroom material should be developed, and when they need to be in place. **1 April 2017**.
- Investigate an instructor development path that includes a partnership with the United States Power Squadron in order to improve coordination between the two groups by **1 June 2017**.
- Develop an annual process for review of educational products to insure they meet public demand by **31 August 2017**.
- From the above plans, develop tactics for building and rolling out new e-courses and for sun-setting obsolete courses. **31 August 2017**.
- Reinforce and update our current product line offering a single certificate generated course (see above) with the others being advanced and more complex, as stand-alone or add-on to the existing certificate course, serving the more mature boater by **1 October 2017**.
- Partner with the USPS to identify areas of collaboration for course development by **1 October 2017**.

Assistant National Commodore – Recreational Boating

Expand efforts in Paddlecraft Water Safety

Goal: Increase Auxiliary presence and relevance in the paddlecraft community.

Activities: Develop paddlecraft safety advocates. Partner with the American Canoe Association (ACA) on public education. Expand existing programs to provide outreach to the paddlecraft community including Vessel Safety Checks (VSCs), Program Visitation (PV), education and an aggressive outreach to outfitters and sales outlets. Expand recruiting efforts in the paddlecraft community. Develop trained paddlecraft vessel examiners and instructors.

Implementing Partners: The Auxiliary, including DNACO-RBS, ANACO-RB, DIR-B, DIR-A, DIR-E, DIR-V, DIR-T, USPS, DIR-R, DIR-I, DIR-A, DIR-H, and DIR-S (AUP), will partner with Assistant Commandant for Prevention Policy (CG-5P), the American Canoe Association (ACA), and Coast Guard Districts.

Tactics and timeline:

- Apply for a grant to fund additional paddlecraft safety outreach activities by **31 December 2017**.
- Expand the Auxiliary Paddlecraft (AUXPAD) program in four Districts; identify coordinators or staff officers in those Districts by **31 December 2016**.
- Work with Coast Guard Operations Training Officers (OTOs) to set goals for number of ACA-qualified instructors; develop associated plan to achieve those goals, **31 December 2016**.
- Set specific goals for paddlecraft Vessel Safety Checks (VSCs) by **31 December 2016**; develop associated plan to achieve those goals by **1 June 2017**.
- Develop a series of paddler profiles and the safety risks to each by **31 December 2017**. Set a timetable for developing outreach and training for each type by **30 June 2017**.
- Set specific goals for offering the public education Paddle Safely class to the public; develop associated plan to achieve those goals by **31 March 2017**.
- Develop data-based information for presentation to the Coast Guard demonstrating the RBS benefits of Auxiliary engagement in paddlecraft missions. By **31 March 2017**.
- Put together a Public Affairs plan that shows the benefits of paddlecraft programs to members by **1 April 2017**.
- Develop a coordination plan with the Response Directorate for AUXPAD underway issues such as Personal Protective Equipment (PPE), Auxiliary Order Management (AOM) use, and visibility by **1 November 2017**.
- Develop guidance to assist Districts in identifying credible people to be trained as Paddlecraft VEs, instructors, and Public Affairs specialists by **1 November 2017**.
- Expand recruiting efforts in the paddlecraft community; develop plans and set recruiting goals by **1 November 2017**.

Assistant National Commodore – ForceCom

Meet Human Capital needs of the Coast Guard and Auxiliary

Goal: Provide qualified members to augment the mission, service and people needs of the Coast Guard.

Activities: Establish contacts with the Coast Guard at the local level to determine what skills and capabilities they need from Auxiliary members as mentors/coaches/tradesman for the support missions of history, clergy, food service, Coast Guard recruiting, ombudsman program, legal, Auxiliary security screening, and other areas as they are identified as needs. Compile a skills list and develop a way to keep the list current. Match Auxiliary based training requirements with the skill levels requested. Define new training as needed and assign the training development to the proper Directorate(s). Develop recruiting techniques to identify potential members with the requested skills. Implement search and sort capability in existing and/or new Auxiliary systems to capable members, and track qualifications and currency.

Implementing Partners: The Auxiliary, including DNACO-MS, ANACO-FC, ANACO-CC, DIR-T, DIR-H, DIR-A, DIR-C, and DIR-Q, will partner with Force Readiness Command (FORCECOM), Assistant Commandant for Human Resources (CG-1), Human Capital Strategy (HSC) Implementation Team, Assistant Commandant for Capability (CG-7), and Coast Guard commands.

Tactics and timeline:

- Develop a plan to establish both the needs at the Coast Guard station/sector level and the capabilities of members around the stations/sectors to meet those needs. The plan will incorporate contacts at the Coast Guard leadership level, District Commodores, Directors of Auxiliary, Auxiliary Unit Coordinators (AUCs) and Auxiliary Sector Coordinators (ASCs) with Auxiliary Liaison Officers. Provide the plan to the National Executive Committee (NEXCOM) for approval by **31 March 2017**.
- Implement the plan in three Districts (west coast, east coast, and inland) as beta sites to establish feasibility of working at the station/sector level. By **30 June 2017**.
- Identify new training to be developed to increase the number of members able to respond to the Coast Guard needs and assign development to the appropriate directorates. By **30 June 2017**.
- Create a web portal that allows ongoing input of needs and requirements from stations/sectors (AUCs/ASCs input) that can be searched by location. By **30 September 2017**.
 - Use this capability to survey members by geography for open positions.
 - Determine if the skills bank or AUXDATA search and sort capability can be expanded for this skills/needs matching.
- Define any organizational changes at the directorate level to integrate this program into ongoing support and development. By **30 September 2017**.
- Based on successful beta tests, extend the skills/needs program to the entire country. Develop a series of ALAUX communications to alert members to the new capabilities. By **30 September 2017**.
- Develop a requirements document outlining the additional data needed from the recruiting process of Auxiliarists to enable search and sort capability to find members with the requisite skills. By **30 September 2017**.
- Develop a requirements document defining what new software capabilities are needed to perform the search and sort if the database existed. By **31 December 2017**.

Assistant National Commodore – Planning and Performance

Expand the Auxiliary University program to meet mission and service needs

Goal: Promote the program to university, Auxiliary, Reserve, and active duty communities. Update the course of study to ensure support of the Auxiliary mission, while providing relevant course delivery. Increase student internships. Align the Auxiliary University Program (AUP) with standard Auxiliary information systems. Improve the leadership aptitude of AUP graduates headed to the Auxiliary, Reserve and active duty.

Activities: Develop future Coast Guard active duty, Reserve, and Auxiliary leaders. Make AUP more managerially sustainable and less resource intensive for the staff. Make AUP simpler and more accessible for the students. Grow the unit and student count in support of Coast Guard human capital needs. Develop a leadership curriculum, training and tools.

Implementing Partners: The Auxiliary, including DNACO-ITP, ANACO-PP, DIR-S, DIR-T, DIR-C, and DCOs, will partner with Director of Governmental & External Affairs (CG-092), FCs, Coast Guard Office of Auxiliary & Boating Safety (CG-BSX), CGRC, and the Office of Research, Development, Test and Evaluation (CG-926).

Tactics and timeline:

- Implement phase one of the leadership development program: alumni association, leadership evaluation reports, advanced track, leadership development framework, and AUP officer qualification by **30 June 2017**.
- Evaluate the success of the leadership development programs that were implemented in phase one by **30 June 2017**.
- Update the Internship Program based on the programs implemented for the first phase of leadership development. By **30 June 2017**.
- Overhaul matriculation to graduation process to eliminate manual workarounds and streamline administration. By **31 August 2017**.
- Based on the evaluation, define and develop the second phase of leadership development programs. Implement for the Fall 2017 semester. By **30 September 2017**.
- Implement college counseling best practices for Unit Officers. By **31 December 2017**.
- Assess feasibility and develop requirements for migrating AUP data onto standard Auxiliary systems. By **31 December 2017**.
- Evaluate the second phase leadership development delivery. By **31 March 2018**.
- Review the Program of Studies curriculum and refresh as needed. **Annually**.
- Continue to work with Coast Guard Recruiting Command on maritime academy expansion. **Ongoing**.
- Share training materials and delivery systems with the Training Directorate, as new material is rolled out. **Ongoing**.
- Work with the Chief Director's office on updates needed to integrate the Auxiliary University Program into the next revision of the Flotilla Procedures Manual. **Date TBD**.

Assistant National Commodore – Planning and Performance

Simplify, standardize and coordinate administrative procedures to meet service and people needs

Goal: Simplify, standardize and coordinate Auxiliary administrative procedures, developing a system of accountability and responsibility, and establishing a formal and coordinated administrative function of management of the Auxiliary's tools, processes and information.

Activities: Review, develop, and systematically execute business processes that support the entire National Staff. Provide life cycle management, in coordination with the Computer Software and Systems and User Support and Services Directorates, of information technology tools required for successful National Staff mission execution. Maintain an archive for easy storage and retrieval of National Staff documents such as quarterly reports, white papers, communication plans, job descriptions, project trackers, original source files for manuals and publications, and external publications.

Implementing Partners: The Auxiliary, including DNACO-ITP, ANACO-PP, ANACO-IT, DIR-C, DIR-U, DIR-S, DIR-SdS, and DIR-SdA, will partner with Assistant Commandant for Command, Control, Communications, Computers & IT (CG-6), Assistant Commandant for Capability (CG-7) and other Directorates as administrative processes are identified that impact them.

Tactics and timeline:

- Develop and prioritize a list of functions, programs and processes to be addressed by the administrative unit by **1 November 2016**.
- Assume management of GoToMeeting scheduling and calendar by **1 November 2016**.
- Develop and implement Servicing Personnel Office (SPO) functions:
 - Develop National Staff personnel recruiting and onboarding process by **31 March 2017**.
 - Assume responsibility for administration of National Staff job board by **date TBD**.
 - Develop template and repository of staff job descriptions by **date TBD**.
- Maintain and audit an electronic document library accessible only to National Staff members and organized in accordance with a common naming convention and taxonomy by **31 March 2017**.
- Develop an implementation timeline for the following functions by **date TBD**:
 - Establish standards and maintain the National Staff Standard Operating Procedures (SOP).
 - Develop and maintain the National Staff Master Calendar.
 - Research, develop, and identify appropriate software tools based on established National Staff operational and functional requirements.
 - Establish clear standards of what is maintained in the archive, and processes as to how documents come to be stored there.
- Define the next phases of work after the first phase is scheduled and underway. **Date TBD**.
 - Execute business processes such as: awards, mailroom (AUXMS), workflow templates and forms in accordance with the SOP.
 - Facilitate implementation of approved software tools from discovery to full operating capability, including software configuration, data migration, and user training.
 - Provide end-users with both automated search and human-assisted information retrieval in support of National Staff projects and research efforts.

Assistant National Commodore – Information Technology

Provide a unified web platform experience to facilitate meeting mission and people needs

Goal: Provide a better experience for members and member leaders, maximizing efficiency and proficiency by automating processes, providing tools and access to information to allow focus on people and missions.

Activities: Define, plan and implement the next phases of the my.cgauX web implementation, including activity tracking, individual and unit AUXDATA and AUXINFO information retrieval, assignment to duty tools, expanded event management capabilities, and directory enhancements. Identify and implement new tools.

Implementing Partners: The Auxiliary, including DNACO-ITP, ANACO-IT, ANACO-PP, ANACO-RB, DIR-S, DIR-C, DIR-U, DIR-V, N-AP, all program managers who have an affected process, and N-EA, will partner with Assistant Commandant for Command, Control, Communications, Computers & IT (CG-6), CG Cyber Command, Assistant Commandant for Capability (CG-7), Coast Guard Office of Auxiliary & Boating Safety (CG-BSX), and RBS partners.

Tactics and timeline:

- Present roadmap for my.cgauX feature and function requests by **31 December 2016**.
- Release version of my.cgauX fully accessible on mobile devices by **NTRAIN 2017**.
- Propose a process to NEXCOM for approval of my.cgauX groups beyond Flotillas, Divisions, and Districts (e.g. National Association of Commodores, Past Division Commanders Association, etc.) by **31 March 2016**.
- Identify an event management strategy integrated with my.cgauX for NACON 2017 by **31 March 2017**.
- Reach agreement with the Coast Guard Operations System Center (OSC), Coast Guard Command, Control, Communications, Computers & IT (CG-6), and the Office of Auxiliary & Boating Safety (BSX) on additional data exchange via AuxBridge to enable member and unit activity visibility in my.cgauX and automated transfer of activity reporting to AUXDATA by **31 March 2017**.
- Present roadmap for direct member activity reporting in my.cgauX by **31 March 2017**.
- Mission Codes – improve and standardize descriptions to be consistent, adhere to policy, and be easy for members to understand and use while providing necessary program data. Support BSX's project to update mission codes and mission code definitions. Prepare and provide training to members and IS officers based on the outcomes of the BSX effort no later than 90 days following completion of the project or any major element.
- Execute quarterly my.cgauX quantitative and qualitative activity analysis for National Executive Committee (NEXCOM). **Ongoing quarterly**
- Execute ongoing my.cgauX engagement training with a quarterly area of focus. **Ongoing**.

National Executive Committee

Identify and provide leadership development resources, tools and training

Goal: Develop world-class Auxiliary leaders

Activities: Identify and provide resources and draft policy to deliver formal training at all levels with an emphasis on practical leadership rather than general management. Leadership training will be available to all members on a regular basis, providing opportunities to learn relevant skills prior to running for office or accepting a staff position. Establish expectations for all office levels based on core competencies. Develop the infrastructure to track leadership training. Develop a method for assessing leadership skills. Promote leaders based on training, experience, and performance, not popularity.

Implementing Partners: The Auxiliary, including Auxiliary National Board, ANACO-FC, ANACO-IT, ANACO-PP, will partner with FORCECOM and the Leadership and Development Center (LDC).

Tactics and timeline:

- Identify a National coordinator, who will be responsible for oversight of all Leadership Initiative work. By **1 November 2016**.
- Charter a new Leadership Guidance Team, including identification of a chairperson and the members. By **1 November 2016**.
- Define the leadership development philosophy. By **1 November 2016**.
- Identify courses and delivery methods. This will be a combination of materials that already exist, which may, or may not need modifications, and new materials. By **NTrain 2017**.
- Outline an assessment process, instrument and implementation timeline. By **NACON 2017**.

National Executive Committee

Standardize, manage and support Auxiliary financial policies and procedures

Goal: Assign a Chief Financial Officer who is responsible for management of Auxiliary National financial strategies and administration.

Activities: Advise the National Commodore on financial matters. Maintain close liaison with District Finance Staff Officers (DSO-FNs). Regularly report financial and budgetary status of the Auxiliary to NEXCOM. Standardize and coordinate the budgeting process for national staff. Develop multi-year plans to support the Auxiliary Strategic Plan. Conduct or review, and approve to NEXCOM, a financial analysis of any strategic or capital program requested by the National staff. Develop and maintain supplemental financial policies and procedures to support those in the Auxiliary Manual. Ensure compliance at all levels with laws and regulations pertaining to financial management. Establish and maintain local audit aids. Provide a force of qualified Auxiliarists to provide personal financial counseling to new Coast Guard members on the blended retirement plan.

Implementing Partners: The Auxiliary, including Auxiliary National Executive Committee (NEXCOM); Guard Auxiliary Association Chairman, Vice Chairman and Executive Director, ANACO-CC and ANACO-IT, will partner with Assistant Commandant for Human Resources (CG-1), Coast Guard Office of Auxiliary & Boating Safety (CG-BSX),; and Coast Guard Reserve and Military Personnel Directorate (CG-13).

Tactics and timeline:

- Develop plans for the following **by 15 March 2017**.
 - First phase of work necessary to support the Strategic Plan.
 - Establishing the needs of the Coast Guard for the number and location of qualified financial counselors on the blended retirement plan.
 - Budgeting process, including long term funding needs, for the National staff.
- Develop an implementation timeline for the above plans **by date TBD**.
- Set format and schedule for regularly reporting financial and budgetary status to NEXCOM **by 30 June 2017**.
- Develop plans for the following **by 30 June 2017**.
 - Understanding the Coast Guard's criteria for financial counselors for the blended retirement plan program. Coordinating the process for identifying and training qualified candidates.
 - Developing and maintaining financial policies and procedures in support of the Auxiliary Manual.
 - Procedures for ensuring compliance with laws and regulations pertaining to financial management.
- Develop an implementation timeline for the above plans **by date TBD**.
- Identify and document any system changes required for tracking and maintaining qualifications of financial counselors **by 30 June 2017**.
- Develop plans for the following **by 30 September 2017**.
 - First phase of coordination activities with DSO-FNs and Districts.
 - Process for financial analysis of strategic and capital program requests.
 - Development of aids for audits of flotilla, division, and district funds.
- Develop an implementation timeline for the above plans **by date TBD**.

National Executive Committee

Provide timely Auxiliary background checks

Goal: Ensure entry-level background checks for Auxiliary members are completed within a four to six month time frame. This is a *U.S. Coast Guard initiative to support the Coast Guard Auxiliary program and members.*

Activities: Identify and provide resources and draft policy to provide timely entry-level background checks for Auxiliary members. Provide and develop a new Coast Guard Office of Auxiliary & Boating Safety (CG-BSX) position to be assigned at the Coast Guard Security Center (SECCEN) which will be focused upon timely processing of entry-level background checks. Ensure the new position description is broad enough in scope to provide flexibility for the position to perform not only its most commonly expected duties of administering Auxiliary entry-level background checks but to also be applied toward other SECCEN background check processing if compelling circumstances like surge operations ever dictate. Ensure that the two Active Duty for Operational Support (ADOS) reservists remain at SECCEN and associated funding is provided for by the Deputy Commandant for Mission Support (DCMS).

Implementing Partners: The Auxiliary will partner with Deputy Commandant for Operations (DCO), DCMS, Office of Security Policy and Management (DCMS-34), Assistant Commandant for Prevention Policy (CG-5P), CG-BSX, and SECCEN.

Tactics and timeline:

- Finalize Position Description for a new CG-BSX GS-13 position to be assigned at SECCEN which will be focused upon the Auxiliary entry level background check process **by date TBD.**
- Identify funding to continue the two ADOS reservists at SECCEN until permanent resources are identified **by date TBD.**
- Establish policy and procedures for conducting Auxiliary background checks **by date TBD.**

National Executive Committee

Enhance the Coast Guard's Auxiliary information system of record to meet mission and service needs

Goal: Develop a world-class system to better maintain and track all Auxiliary members and facilities. This is a *U.S. Coast Guard initiative to support the Coast Guard Auxiliary program and members.*

Activities: Identify and provide resources and draft policy to provide the Auxiliary with a state of the art management database for maintaining and tracking all personnel and facilities. Provide a database that is Windows 10 friendly and will adhere to all cyber security requirements.

Implementing Partners: The Auxiliary will partner with Deputy Commandant for Operations (DCO), Deputy Commandant for Mission Support (DCMS), Assistant Commandant for Prevention Policy (CG-5P), Coast Guard Office of Auxiliary & Boating Safety (CG-BSX), Assistant Commandant for Capability (CG-7), Coast Guard Office of C4 & Sensors Capabilities (CG-761), Coast Guard Operations System Center (OSC), Assistant Commandant for Command, Control, Communications, Computers & IT (CG-6), and Office of Enterprise Applications Management (CG-63).

Tactics and timeline:

- Identify approximately \$1.3M in recurring funding to establish an annual AUXDATA operating base that has the capacity, flexibility, and security to properly meet the information system needs of the CG's 27,600 Auxiliarists **by date TBD.**



United States Coast Guard Auxiliary

<http://www.cgaux.org>